

Autonics

INDUCTIVE PROXIMITY SENSOR

LONG DISTANCE CYLINDRICAL TYPE DC 3WIRE

M A N U A L



Thank you very much for selecting Autonics products.
For your safety, please read the following before using.

Caution for your safety

- ※Please keep these instructions and review them before using this unit.
 - ※Please observe the cautions that follow:
 - Warning** Serious injury may result if instructions are not followed.
 - Caution** Product may be damaged, or injury may result if instructions are not followed.
 - ※The following is an explanation of the symbols used in the operation manual.
 - Caution:** Injury or danger may occur under special conditions.
- Warning**
- In case of using this unit with machineries(Nuclear power control, medical equipment vehicle, train, airplane, combustion apparatus, entertainment or safety device etc), it requires installing fail-safe device, or contact us for information on type required.
It may result in serious damage, fire or human injury.

Caution

- Do not use this unit in place where there are flammable, explosive gas, chemical or strong alkalis, acids.
It may cause a fire or explosion.
- Do not impact on this unit.
It may result in malfunction or damage to the product.
- Do not apply AC power and observe specification rating.
It may result in serious damage to the product.

Ordering information

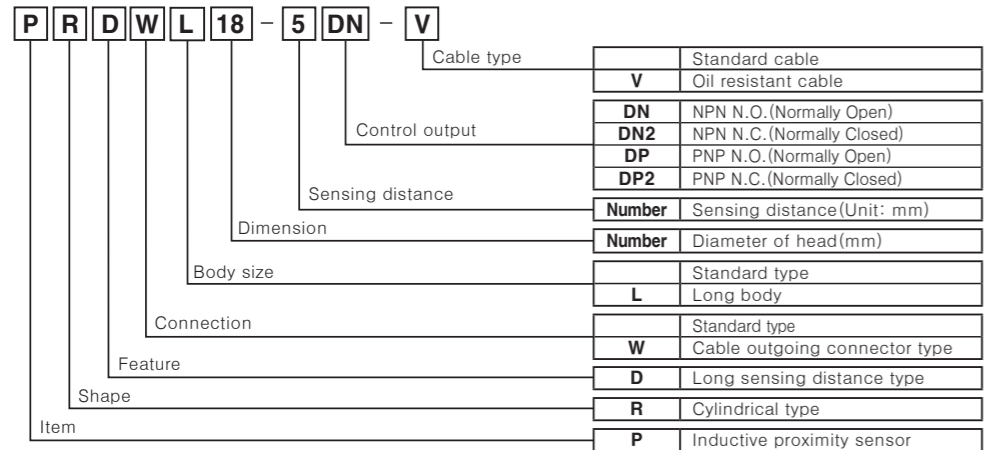

Control output diagram & Load operating

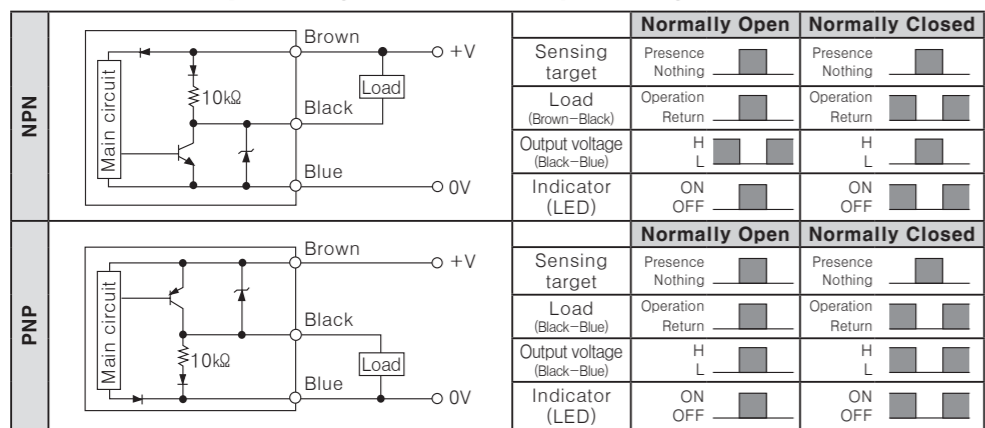

※ The above specifications are subject to change without notice.

Specifications

Model	PRD12-4DN PRD12-4DP PRD12-4DN2 PRD12-4DP2 PRDL12-4DN PRDL12-4DP PRDL12-4DN2 PRDL12-4DP2 PRDW12-4DN PRDW12-4DP PRDW12-4DN2 PRDW12-4DP2 PRDWL12-4DN PRDWL12-4DP PRDWL12-4DN2 PRDWL12-4DP2 PRDW12-4DN-V PRDW12-4DP-V	PRD12-8DN PRD12-8DP PRD12-8DN2 PRD12-8DP2 PRDL12-8DN PRDL12-8DP PRDL12-8DN2 PRDL12-8DP2 PRDW12-8DN PRDW12-8DP PRDW12-8DN2 PRDW12-8DP2 PRDWL12-8DN PRDWL12-8DP PRDWL12-8DN2 PRDWL12-8DP2 PRDW12-8DN-V PRDW12-8DP-V	PRD18-7DN PRD18-7DP PRD18-7DN2 PRD18-7DP2 PRDL18-7DN PRDL18-7DP PRDL18-7DN2 PRDL18-7DP2 PRDW18-7DN PRDW18-7DP PRDW18-7DN2 PRDW18-7DP2 PRDWL18-7DN PRDWL18-7DP PRDWL18-7DN2 PRDWL18-7DP2 PRDW18-7DN-V PRDW18-7DP-V	PRD18-14DN PRD18-14DP PRD18-14DN2 PRD18-14DP2 PRDL18-14DN PRDL18-14DP PRDL18-14DN2 PRDL18-14DP2 PRDW18-14DN PRDW18-14DP PRDW18-14DN2 PRDW18-14DP2 PRDWL18-14DN PRDWL18-14DP PRDWL18-14DN2 PRDWL18-14DP2 PRDW18-14DN-V PRDW18-14DP-V	PRD30-15DN PRD30-15DP PRD30-15DN2 PRD30-15DP2 PRDL30-15DN PRDL30-15DP PRDL30-15DN2 PRDL30-15DP2 PRDW30-15DN PRDW30-15DP PRDW30-15DN2 PRDW30-15DP2 PRDWL30-15DN PRDWL30-15DP PRDWL30-15DN2 PRDWL30-15DP2 PRDW30-15DN-V PRDW30-15DP-V	PRD30-25DN PRD30-25DP PRD30-25DN2 PRD30-25DP2 PRDL30-25DN PRDL30-25DP PRDL30-25DN2 PRDL30-25DP2 PRDW30-25DN PRDW30-25DP PRDW30-25DN2 PRDW30-25DP2 PRDWL30-25DN PRDWL30-25DP PRDWL30-25DN2 PRDWL30-25DP2 PRDW30-25DN-V PRDW30-25DP-V
Sensing distance	4mm	8mm	7mm	14mm	15mm	25mm
Hysteresis	Max. 10% of sensing distance					
Standard sensing target	12×12×1mm (Iron)	25×25×1mm (Iron)	20×20×1mm (Iron)	40×40×1mm (Iron)	45×45×1mm (Iron)	75×75×1mm (Iron)
Setting distance	0~2.8mm	0~5.6mm	0~4.9mm	0~9.8mm	0~10.5mm	0~17.5mm
Power supply (Operating voltage)	12~24VDC (10~30VDC)					
Current consumption	Max. 10mA					
Response frequency (※1)	500Hz	400Hz	300Hz	200Hz	100Hz	100Hz
Residual voltage	Max. 1.5V					
Affection by Temp.	Within ±10°C max. of sensing distance at temperature range of -25 ~ 70°C					
Control output	Max. 200mA					
Insulation resistance	Min. 50MΩ (500VDC megger)					
Dielectric strength	1,500VAC 50/60Hz for 1 minute					
Vibration	1mm amplitude at frequency of 10 ~ 55Hz in each of X, Y, Z directions for 2 hours					
Shock	500※ (50G) X, Y, Z directions for 3 times					
Indicator	Operating indicator (Red LED)					
Environment	Ambient temperature: -25 ~ 70°C, Storage: -30 ~ 80°C Ambient humidity: 35 ~ 95%RH, Storage: 35 ~ 95%RH					
Protection circuit	surge protection, Reverse polarity protection, overload & short circuit protection					
Protection	IP67 (IEC Standards)					
Materials	Case/Nut: Nickel plated Brass, Washer: Nickel plated Iron, Sensing surface: Heat-resistant ABS, Standard cable (Black): Polyvinyl chloride (PVC), Oil resistant cable (Gray): Oil resistant Polyvinyl chloride (PVC)					
Approval	CE					
Unit Weight	PRD: Approx. 74g PRDL: Approx. 94g PRDW: Approx. 44g PRDWL: Approx. 64g	PRD: Approx. 72g PRDL: Approx. 92g PRDW: Approx. 42g PRDWL: Approx. 62g	PRD: Approx. 115g PRDL: Approx. 145g PRDW: Approx. 80g PRDWL: Approx. 110g	PRD: Approx. 110g PRDL: Approx. 140g PRDW: Approx. 75g PRDWL: Approx. 105g	PRD: Approx. 175g PRDL: Approx. 215g PRDW: Approx. 140g PRDWL: Approx. 180g	PRD: Approx. 180g PRDL: Approx. 220g PRDW: Approx. 145g PRDWL: Approx. 185g

※ 1: The response frequency is the average value. The standard sensing target is used and the width is set as 2 times of the standard sensing target, 1/2 of the sensing distance for the distance.
 ※ Environment resistance is rated at no freezing or condensation.

Dimensions

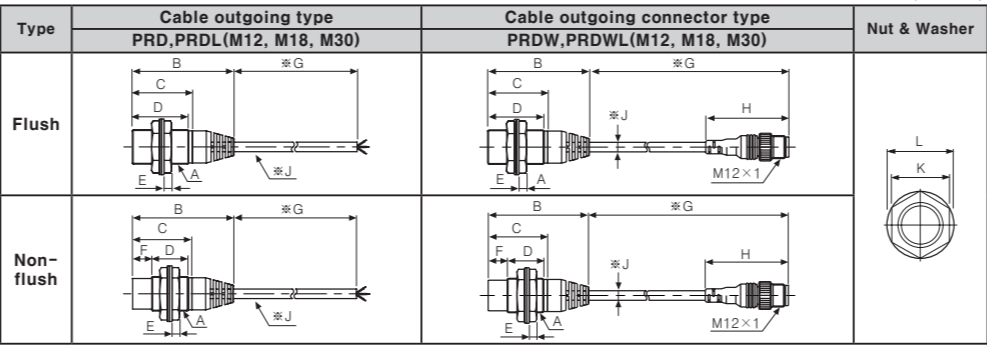

Type		A	B	C	D	E	F	G	H	J	K	L
Flush	M12	PRD M12×1	51.8	33.5	31.5	4	—	2,000	—	4	17	21
		PRDW M12×1	51.8	33.5	31.5	4	—	300	44	4		
		PRDL M12×1	64.3	46	44	4	—	2,000	—	4		
		PRDWL M12×1	64.3	46	44	4	—	300	44	4		
Flush	M18	PRD M18×1	53.2	31.5	29.5	4	—	2,000	—	5	24	29
		PRDW M18×1	53.2	31.5	29.5	4	—	300	44	5		
		PRDL M18×1	85.7	64	62	4	—	2,000	—	5		
		PRDWL M18×1	85.7	64	62	4	—	300	44	5		
Flush	M30	PRD M30×1.5	62	40.3	38	5	—	2,000	—	5	35	42
		PRDW M30×1.5	62	40.3	38	5	—	300	44	5		
		PRDL M30×1.5	84	62.3	60	5	—	2,000	—	5		
		PRDWL M30×1.5	84	62.3	60	5	—	300	44	5		
Non-flush	M12	PRD M12×1	51.8	33.5	24.5	4	7	2,000	—	4	17	21
		PRDW M12×1	51.8	33.5	24.5	4	7	300	44	4		
		PRDL M12×1	64.3	46	37	4	7	2,000	—	4		
		PRDWL M12×1	64.3	46	37	4	7	300	44	4		
Non-flush	M18	PRD M18×1	52.7	31	19	4	10	2,000	—	5	24	29
		PRDW M18×1	52.7	31	19	4	10	300	44	5		
		PRDL M18×1	85.7	64	52	4	10	2,000	—	5		
		PRDWL M18×1	85.7	64	52	4	10	300	44	5		
Non-flush	M30	PRD M30×1.5	62	40.3	28	5	10	2,000	—	5	35	42
		PRDW M30×1.5	62	40.3	28	5	10	300	44	5		
		PRDL M30×1.5	84	62.3	50	5	10	2,000	—	5		
		PRDWL M30×1.5	84	62.3	50	5	10	300	44	5		

※ *G* type standard : Cable outgoing type/2,000mm, Cable outgoing connector type/300mm
 ※ *J* type : φ4, 3 cores / φ5, 3 cores (Conductor cross section: 0.3mm², Insulator diameter: φ1.25)

Connections

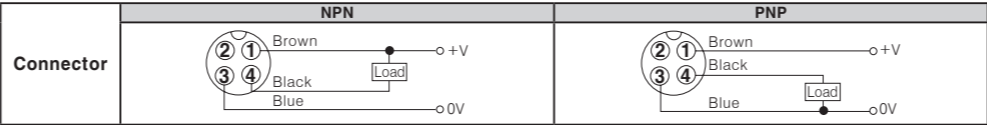

Mutual-interference & Influence by surrounding metals

Mutual-interference
 When several proximity sensors are mounted closely, malfunction of sensor may be caused due to mutual interference. Therefore, be sure to provide a minimum distance between the two sensors with referring to the chart below.



Influence by surrounding metals
 When sensors are mounted on metallic panel, it is required to protect the sensors from being affected by any metallic object except target. Therefore, be sure to provide a minimum distance as below chart.

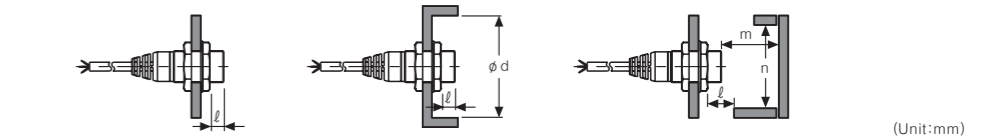

Item	Model PRD□12-4□ PRDW□12-4□	PRD□12-8□ PRDW□12-8□	PRD□18-7□ PRDW□18-7□	PRD□18-14□ PRDW□18-14□	PRD□30-15□ PRDW□30-15□	PRD□30-25□ PRDW□30-25□
A	24	48	42	84	90	150
B	24	36	36	54	60	90
ℓ	0	11	0	14	0	15
φd	12	36	18	54	30	90
m	12	24	21	42	45	75
n	18	36	27	54	45	90

Setting distance

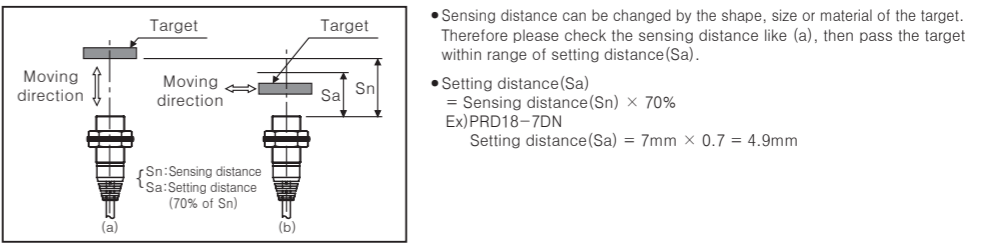

Caution for using

- This equipment shall not be used outdoors or beyond specified temperature range.
 - Do not apply over tensile strength of cord. (φ4: 30N max., φ5: 50N max.)
 - Do not use the same conduit with cord of this unit and electric power line or power line.
 - Do not put overload to tighten nut, please use the supplied washer for tightening.
- Head
- Front
- Rear
- washer
- mounting bracket
- | Model | Strength | Front | | Rear |
|--------------|-----------|-------|-----------|------------|
| | | Size | Torque | Torque |
| PRD12 Series | Flush | 13mm | 65kgf·cm | 120kgf·cm |
| | Non-flush | 7mm | (6.37N·m) | (11.76N·m) |
| PRD18 Series | Flush | — | — | 150kgf·cm |
| | Non-flush | — | — | (14.7N·m) |
| PRD30 Series | Flush | 26mm | 500kgf·cm | 800kgf·cm |
| | Non-flush | 12mm | (49N·m) | (78.4N·m) |
- [Table 1]
- Note1) Allowable tightening torque of a nut may be different by the distance from the head. For allowable tightening torque and the range of front and rear parts, refer to [Table 1] and above [Picture 1] respectively. The rear part includes a nut on the head side (see above [Picture 1]). Please apply a tightening torque of the front part when the nut on the front is located in the front part.
- Note2) The allowable tightening torque denotes a torque value when using a provided washer as above [Picture 2].
- Please check the voltage changes of power source in order not to exceed rating power input.
 - Do not use this unit during transient time (80ms) after apply power.
 - It may result in damage to this product, if use automatic transformer. So please use insulated transformer.
 - Please make wire as short as possible in order to avoid noise.
 - Be sure to use cable as indicated specification on this product. If wrong cable or bended cable is used, it shall not maintain the water-proof.
 - It is possible to extend cable with over 0.3mm² and max. 200m.
 - If the target is plated, the operating distance can be changed by the plating material.
 - It may result in malfunction by metal particle on product.
 - If there are machines (motor, welding etc), which occurs big surge around this unit, please install the varistor or absorber to source of surge, even though there is built-in surge absorber in this unit.
 - If connecting the load with big inrush current (DC type bulb) to this unit, the big inrush current will flow since the initial resistance is low. If the current flows, the resistance of load will be bigger, then it will return to standard current. In this case, proximity sensor might be damaged by inrush current.
 - If you use DC type bulb, please connect extra relay or resistance in order to protect proximity sensor from.
 - If making a transceiver close to proximity sensor or wire connection, it may cause malfunction.
- ※ It may cause malfunction if above instructions are not followed.**

Major products

- Proximity sensors
- Area sensors
- Photoelectric sensors
- Fiber optic sensors
- Door/Door side sensors
- Sensor controllers
- Graphic/Logic panels
- Temperature controllers
- Tachometer/Pulse(Rate) meters
- Temperature/Humidity transducers
- Switching power supplies
- Stepping motors/drivers/motion controllers
- Field network devices
- Laser marking system (CO₂, Nd:YAG)
- Laser welding/soldering system
- Counters
- Timers
- Display units
- Panel meters
- Pressure sensors
- Rotary encoders
- Power controllers

Autonics Corporation
<http://www.autonics.com>

Satisfiable Partner For Factory Automation

■ HEAD QUARTERS :
 41-5, Yongdang-dong, Yangsan-si, Gyeongnam, 626-847, Korea

■ OVERSEAS SALES :
 Bldg. 402 3rd FL., Bucheon Techno Park, 193, Yakdae-dong, Wornmi-gu, Bucheon-si, Gyeonggi-do, 420-734, Korea
 TEL : 82-32-610-2730 / FAX : 82-32-329-0726

■ E-mail : sales@autonics.com

The proposal of a product improvement and development : product@autonics.com